

Portfolio

Emma Johnson
2026

Table of Contents

Envision War's Blight **4**

Zaplutîca **8**

ORIS **10**

2025 Dakota Days Button Designs **11**

Mental Health Matters (MHM) **12**

Rekovr **14**

USD Art Department Promotional Booklet **18**

Bloodline **20**

Résumé

Contact Information

(605) 370-4222
emmajohnson160@gmail.com | @ej_visual.graphics

Education

Bachelor of Fine Arts, Graphic Design Minor in Art History

University of South Dakota
Vermillion, South Dakota

Dean's List, Aug 2022–present

Graduation expected May 2026

Memberships

- USD AIGA Secretary, 2023–2024
- Saint Thomas More Newman Center Advisory Council, Aug 2024–Jan 2026

Software

- Adobe Photoshop
- Adobe Illustrator
- Adobe InDesign
- Adobe After Effects
- Adobe Premiere Pro
- Adobe Acrobat
- Adobe XD
- Audacity
- Figma
- HubSpot
- Wix
- Microsoft Word
- Microsoft PowerPoint
- Keynote
- Miro

Experience

Design Intern | Mitchell Catholic Parishes, Remote | Dec 2025–present

- Structure layout and compose copy for print and digital publications
- Maintain brand consistency across media and projects
- Present project development regularly

Freelance Designer | Vermillion, South Dakota | Aug 2024–present

- Create t-shirt designs and mural designs for walls
- Generate brand identities and posters for events
- Develop environmental graphics and outdoor advertising materials for fundraiser events

Junior Designer | USD Marketing & Creative Services,
Vermillion, South Dakota | Aug 2024–Dec 2025

- Designed university materials
- Printed, trimmed, mounted, and laminated materials
- Partnered with clients to understand and achieve vision

Design Consultant | USD Coyote Business Consulting,
Vermillion, South Dakota | Aug–Nov 2024

- Collaborated with a team of business students
- Updated website for South Dakota Trade using HubSpot
- Constructed standard operating procedures for how to use WISERTrade Database and manage data in Excel

Honors & Awards

- 39th Annual Juried Stilwell Student Award Exhibition, Jan 2025
- Stilwell des Refusés, Jan 2025

About Me

Emma Johnson

I grew up in the very small town of **Montrose, South Dakota**. I've always had a **love of art** and **creativity**, but most **especially storytelling**—whether that was in the form of movies, books, or video games. I was always **immersing myself in different worlds** as a kid. I think there is something so fascinating and beautiful about being able to experience and insert oneself into a different, vast universe.

I am proud to say my grandpa is a farmer, and I was able to spend a lot of my childhood outside on the farm. My siblings, cousins, and I could always find a way to **entertain ourselves with our surroundings**, no matter how mundane they were. When we put our imaginations together, there was nothing we could not do or no one we could not be.

Family is one of the most important and inspiring things in my life. I am lucky enough to have grown up with three incredible siblings. As the **youngest member of my family**, I have always **looked up to my older siblings**. Looking back, they have inspired me in numerous ways and have had an enormous **influence on who I have become**. My imagination and creativity thrive when I am around them. They have a way of increasing my enthusiasm and bringing out my creative side.

Envision War's Blight

Scope

The scope of this project was to choose an ongoing crisis and display information about it using infographics on a large-format poster, in addition to three AR posters and an explainer video. At the end of the project, each student presented their work to professional designers.

Methodology

This was my first time working on an illustration-based project, and I was eager to lean into the aspect of storytelling. For the global crisis, I chose the Russia-Ukraine conflict, and I came up with a plot to help me think about what I could illustrate and how I could display my research. I created a speculative vision of the conflict by imagining a haunting future where fallen soldiers have reanimated, unleashing chaos across the city of Kyiv, Ukraine. Through this fictional lens, the project explores the lingering consequences of war and uses the metaphor of reanimation to symbolize how the destruction of war refuses to stay buried.

Results/Learning

Throughout this project, I relearned how well I work when I do not compare others' projects to my own. I also gained confidence in how to effectively present and communicate my thought process and walk others through my project in a way that is easy to understand.



Envision War's Blight Cont.

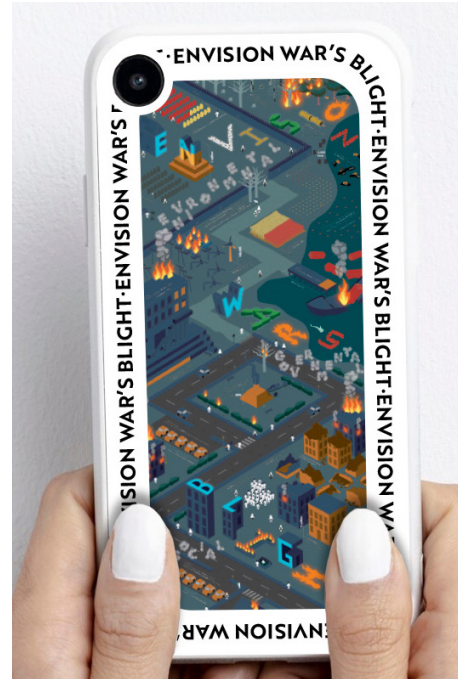
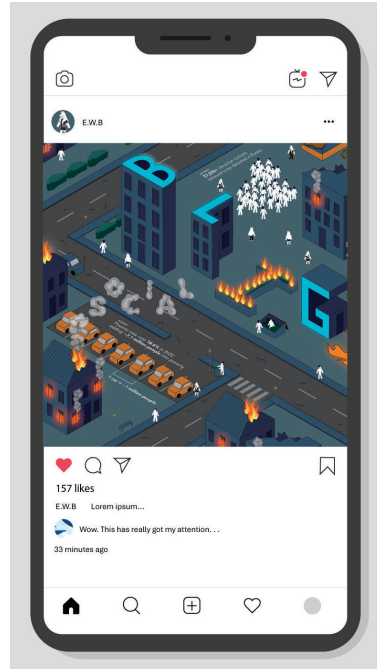

AR Posters (Scan with Artivive)



Slogan Elements

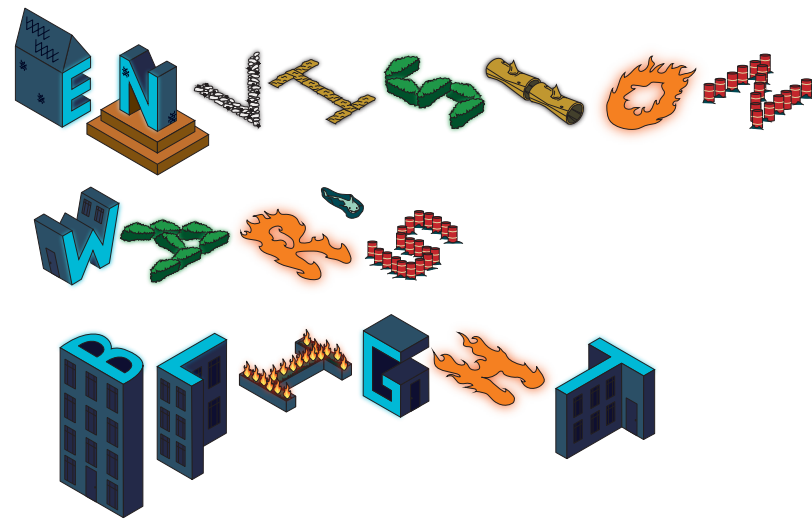

Reanimated Soldiers



Zaplutîca

Scope

The scope of this project was to create a cohesive brand identity and visual style for a fictional telecommunications company called Zaplutîca. This included developing a logo, color palette, and other graphic elements such as a pattern that reflected the brand's values, mission, and target audience. The project involved designing key brand assets, stationery, ephemera, collateral materials, and a brand standards guide.

Methodology

The first part of this project consisted of researching the telecommunications market and creating a competitive and visual audit. Next, I started sketching and ideating logos. From there, I developed design assets and brand materials. Lastly, guidelines were created to prevent improper use of the brand elements.

Results/Learning

I learned what the process of developing a brand consists of and how much time, energy, and thought it takes. My main takeaway was that the logo itself is not the brand.

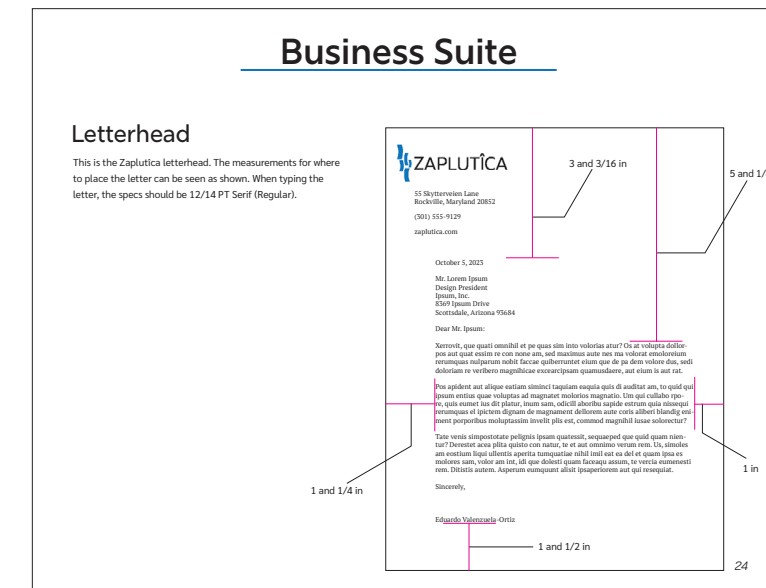
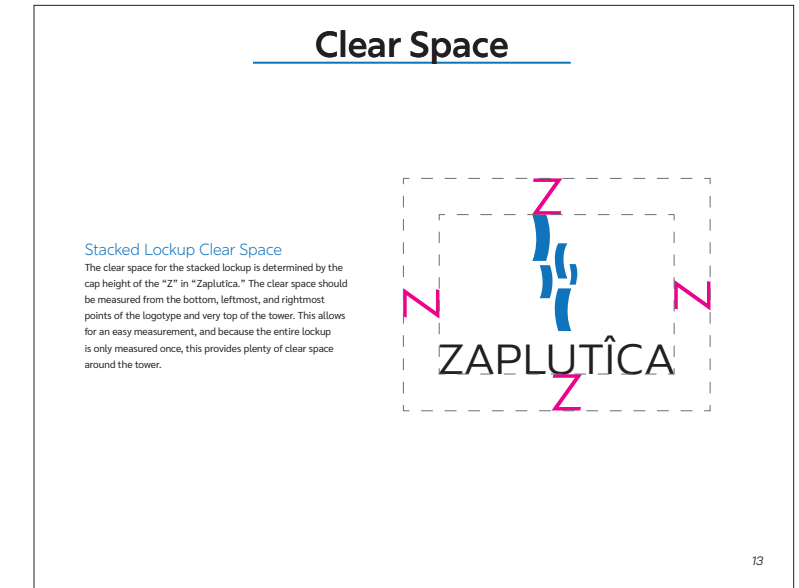

Early Logo Iterations

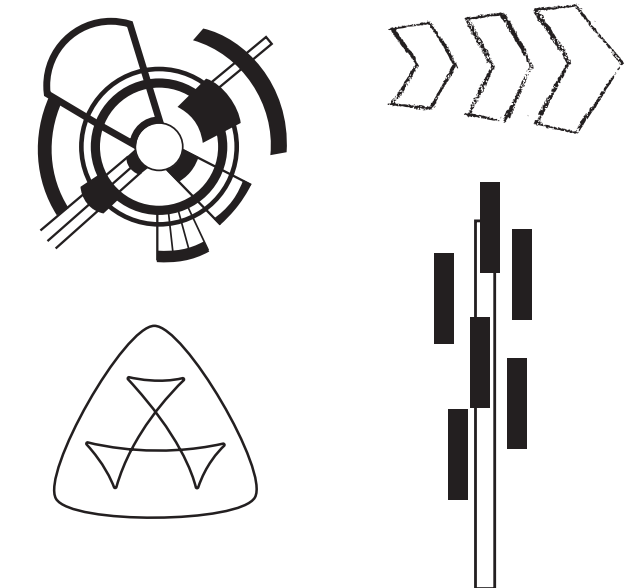

ORIS

Scope

The scope of this project was to create a subsidiary for Zaplutica. I was given a cloud storage company called On-Ramp Internet Services. After developing the brand identity, I needed to create a product marketing sheet for the company.

Methodology

The research process consisted of researching the market and creating a competitive and visual audit. Next, I began sketching logo ideas. Luckily, I was able to shorten my company name to ORIS. Once a logo idea was solidified, I began tweaking the logo and making numerous iterations. After my mark, type, and colors were finalized, I created and branded the product marketing sheet.

Results/Learning

I learned how important ideating and iterating are when creating logos. This project was a great opportunity to work on making decisions about which design directions to pursue and which to abandon.

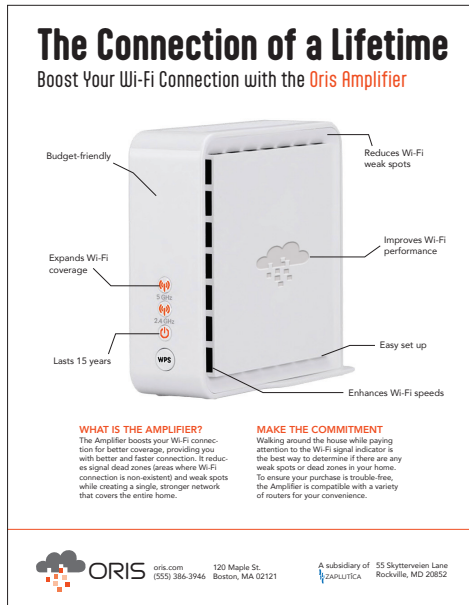

Early Logo Iterations

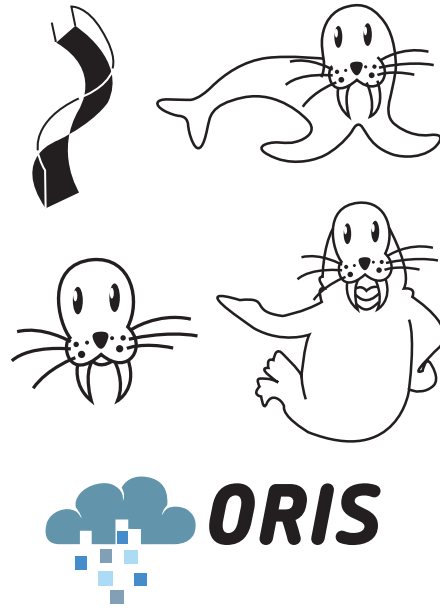

2025 Dakota Days Button Designs

Scope

The purpose of this project was to design a button pin for the University of South Dakota's Dakota Days. This button was for people of all ages, from kids to college students and alumni.

Methodology

The University of South Dakota recently updated their coyote logo, so I used this to my advantage. I started iterating until I could not iterate anymore. Then came the difficult part: making a decision.

Results/Learning

This was another project where I got to practice and continue to learn which designs needed to be abandoned.



Mental Health Matters (MHM)

Scope

The scope of this project was to create a website and app about a topic related to Gen Z and show how to navigate them with prototyping. The topic I chose was mental health. Once completed, each student presented their project to professional designers.

Methodology

The process for this project started with researching the topic, deciding what the app and website would offer, and creating an affinity map by brainstorming all the different pages the app and website would require. Then I began developing a logo and design assets. After putting together the website and app in Figma, I prototyped them to show how they would be used.

Results/Learning

I found this project to be informative. It made me think about and wrestle with type and picture treatment. Not only did the design need to be appealing, but it needed to be functional as well.

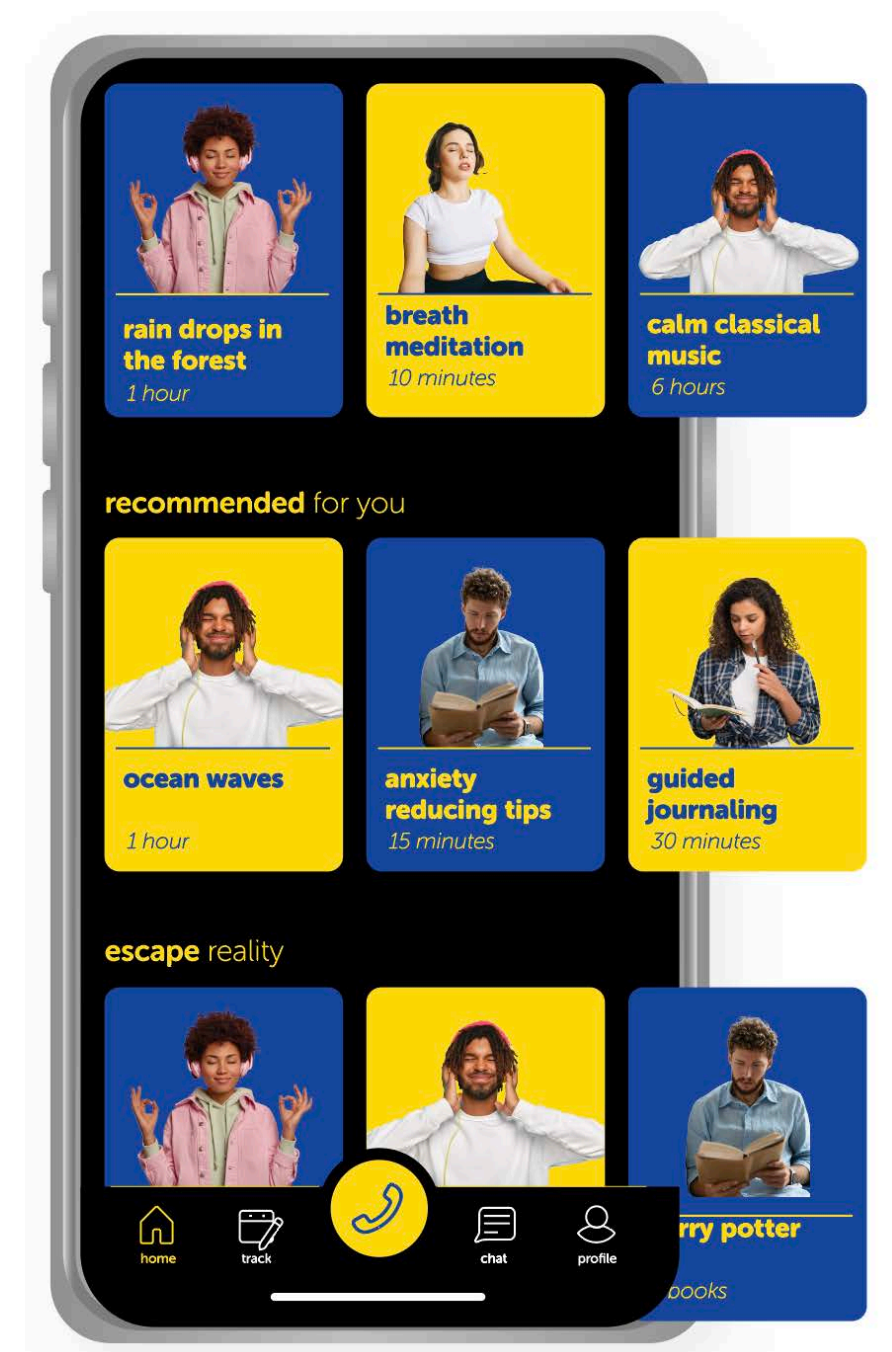
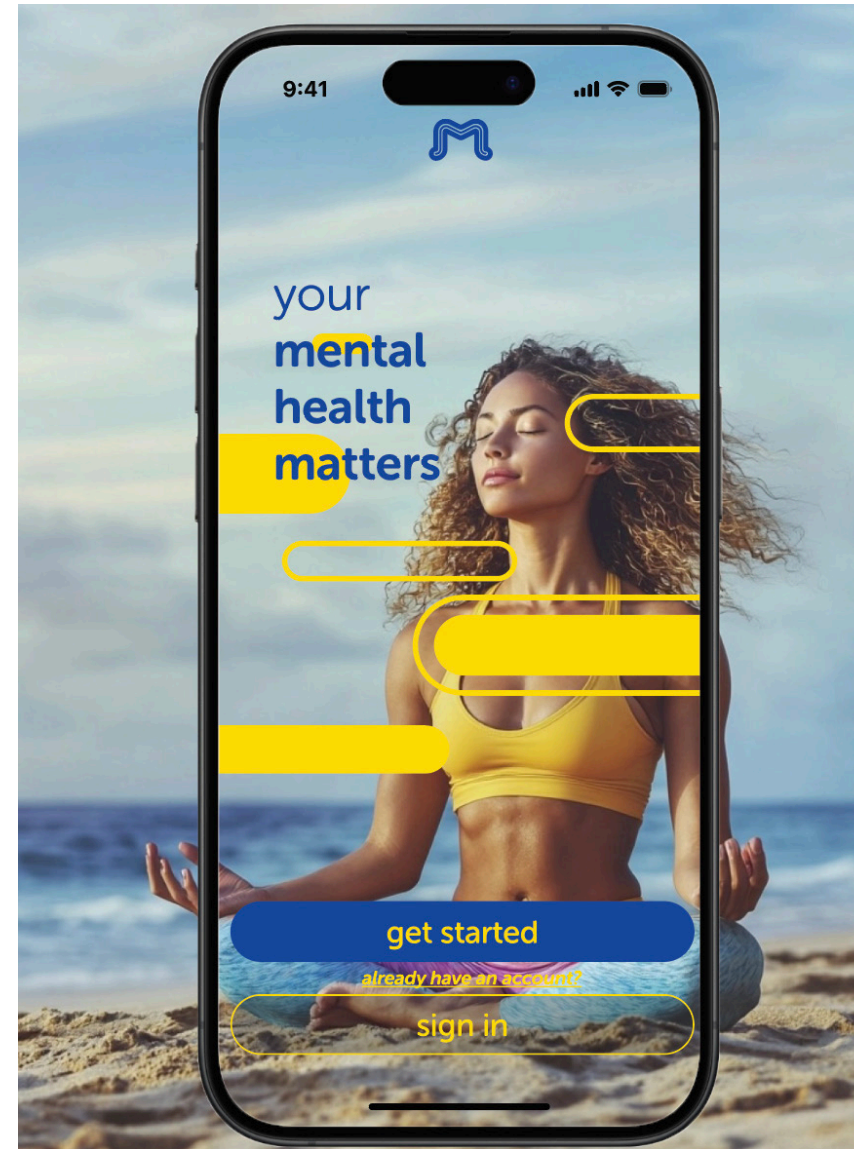

Rekovr

Scope

The scope of the project was to create sustainable package designs for three different kinds of drinks, nuts, and fruits. Each product needed dielines and surface graphics. Next, each product needed to be constructed and photographed. Finally, at the end of the project, each student presented their work to professional designers.

Methodology

Similar to the other projects, this one started with researching, sketching, and digitizing. Once I had a concept down, I researched different dielines and created the surface graphics. After printing the surface graphics and constructing/purchasing the containers, I set them up to take pictures.

Results/Learning

My biggest takeaway from this project was how designs need to be supported by research. There must be a reason why you choose to design in a specific way, not just because of how it looks. This was also my first time presenting my work to people other than classmates, so I got to practice my public speaking skills.

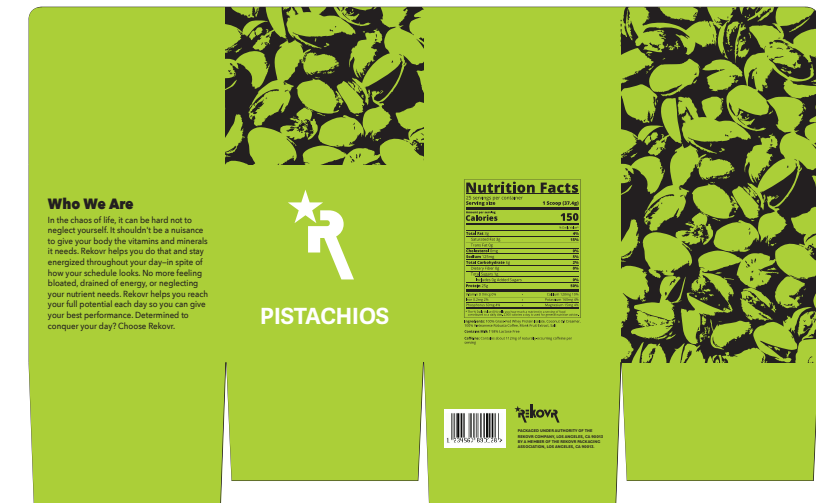
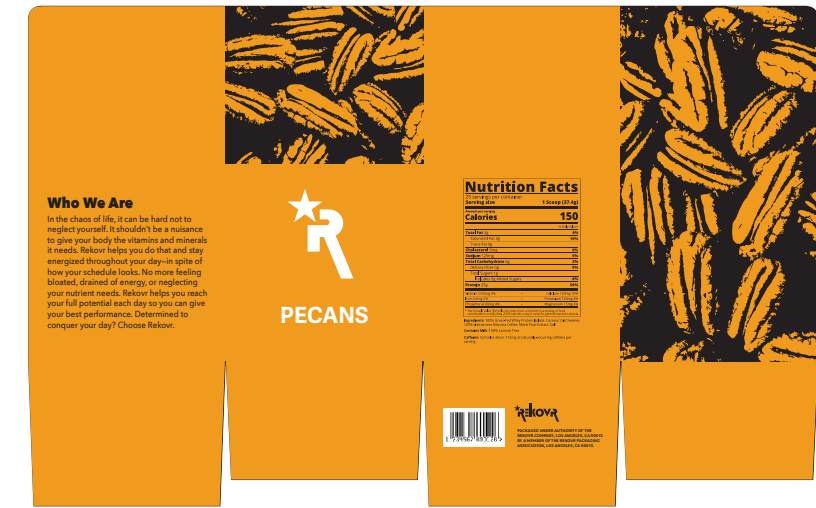
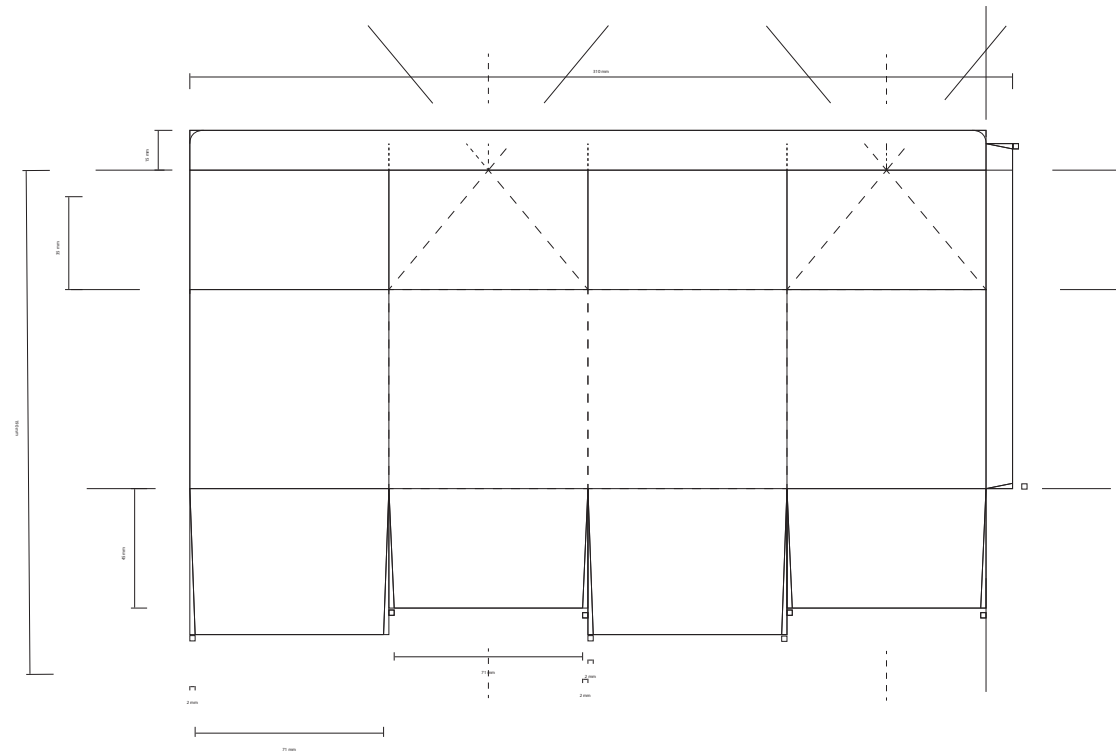

Rekovr Cont.

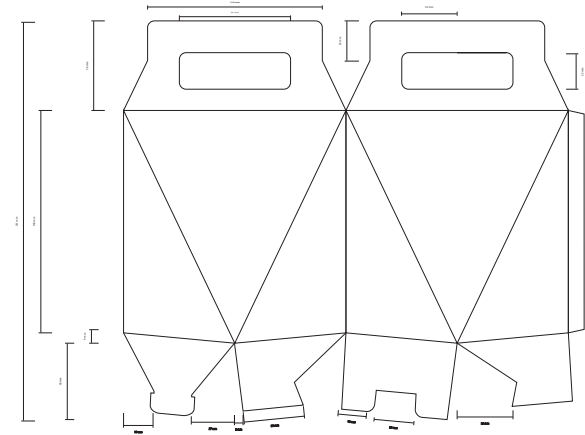
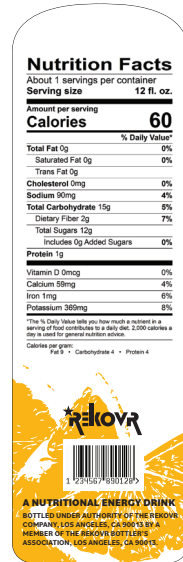
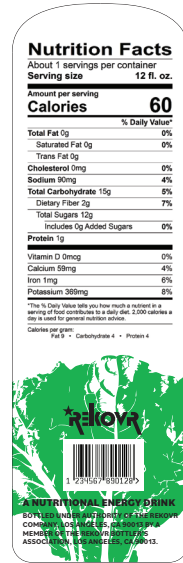
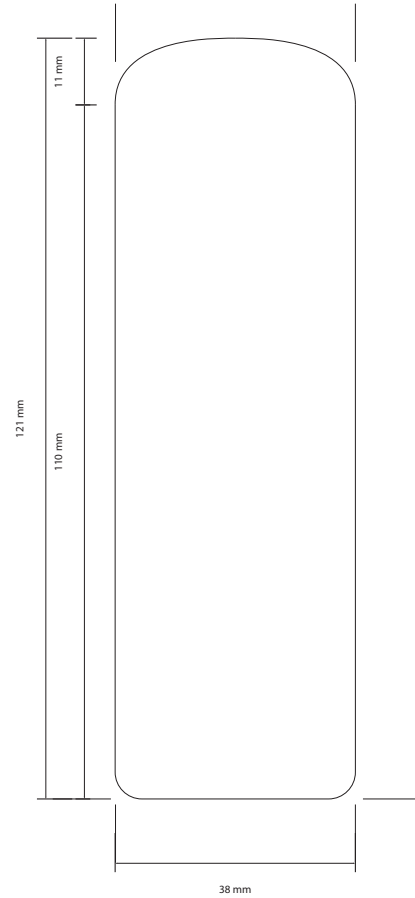

USD Art Department Promotional Booklet

Scope

The scope of this project was to create a promotional booklet with a group for the USD Fine Arts Center on campus. The goal was to be able to hand this booklet out to touring high school students so they could learn about the different art specializations USD offers.

Methodology

We approached this project by dividing the pages among our group of three. Before designing, we sat together researching and discussing what we wanted our magazine to look like and how we were going to ensure the design remained cohesive. After finalizing the design, I ordered a handful of our booklets from USD's copy center.

Contribution

My contribution to the magazine consisted of designing the spreads for ceramics, sculpture, and the table of contents. After solidifying our designs for the inside spreads, I created the covers.

Results/Learning

This project allowed me to practice my communication skills and manage a group. Keeping a cohesive look with two other designers was not easy. Another thing I learned was how to impose pages for booklet building.

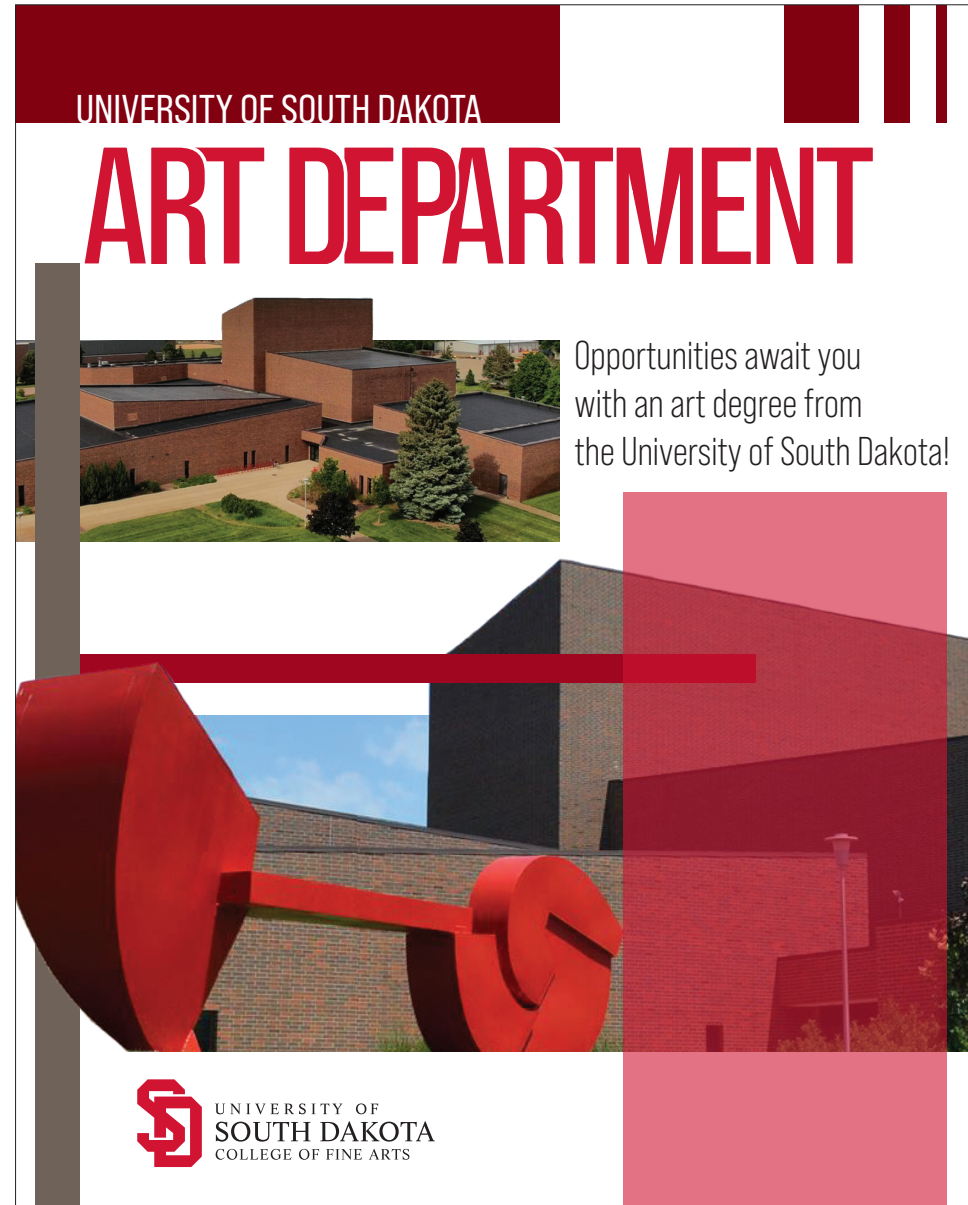

Opportunities await you with an art degree from the University of South Dakota!

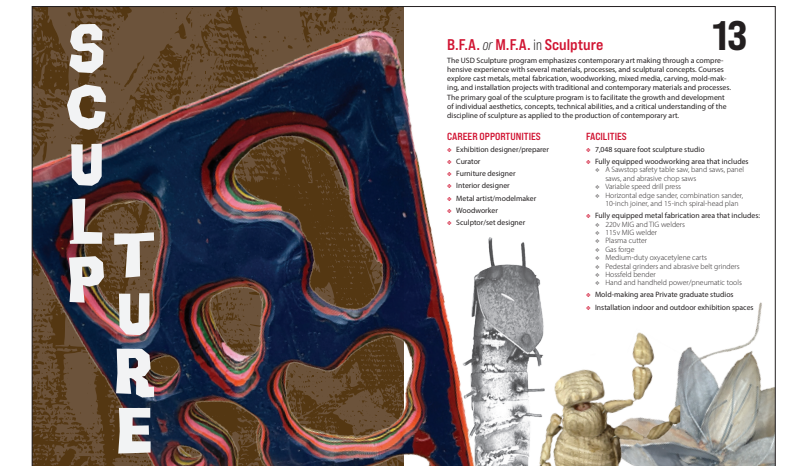

Bloodline

Scope

Bloodline was about combining my love for video games, worldbuilding, and design by developing a plot and turning it into a brand. The world is heavily influenced by vampire folklore and Gothic architecture, which have always fascinated me. The story takes place in 1473 Wallachia and follows Gideon Valoros as he navigates the Transylvanian wilderness to find his captured wife. To explain all the nitty-gritty details, I created an in-depth visual dictionary.

Methodology

When I started developing the story, I focused on creating a central conflict and asked myself why the problem exists, how it started, and how it might be resolved. That process helped shape both the narrative and the world itself. I created a visual dictionary because I was inspired by how my Star Wars visual dictionaries broke down the world, characters, and designs in a way that made the universe feel more real. Finally, for the creature designs, I looked back at monster drawings my siblings and I came up with as kids. I created all the illustrations with pencil and ink on paper, and I was able to digitize them in Photoshop.

Results/Learning

Throughout this project, I was able to work on developing copy and ensuring consistency throughout the publication. Bloodline has also helped me brush up on my drawing skills.

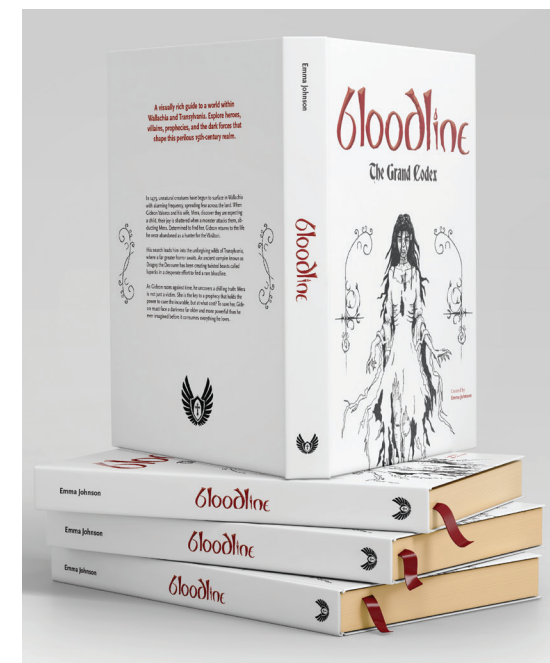
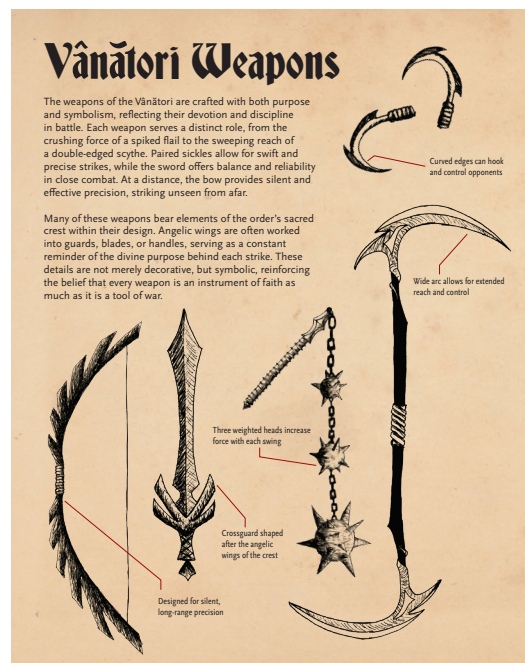

EM

Thank you!

(605) 370-4222

emmajohnson160@gmail.com

[@ej_visual.graphics](#)